



COVER SHEET	
ELEVATION SHEET	
SECTION DETAILS (MECHANICALLY ASSEMBLY)	SG-1
SECTION DETAILS (MECHANICALLY ASSEMBLY)	SG-2
SECTION DETAILS (WELDED ASSEMBLY)	SG-3
SECTION DETAILS (WELDED ASSEMBLY)	SG-4
SECTION DETAILS (DOOR ASSEMBLY)	SG-5
SECTION DETAILS (OPERABLE VENT ASSEMBLY)	SG-6
GLAZING OPTIONS	SG-7
RECEPTOR OPTION	SG-8
I-VALUES	SG-9
SPECIFICATIONS	

STRUCTURAL GLAZE



StileLine

Steel Storefront Systems
A Division of Stiles Custom Metal, Inc.

www.StileLine.com

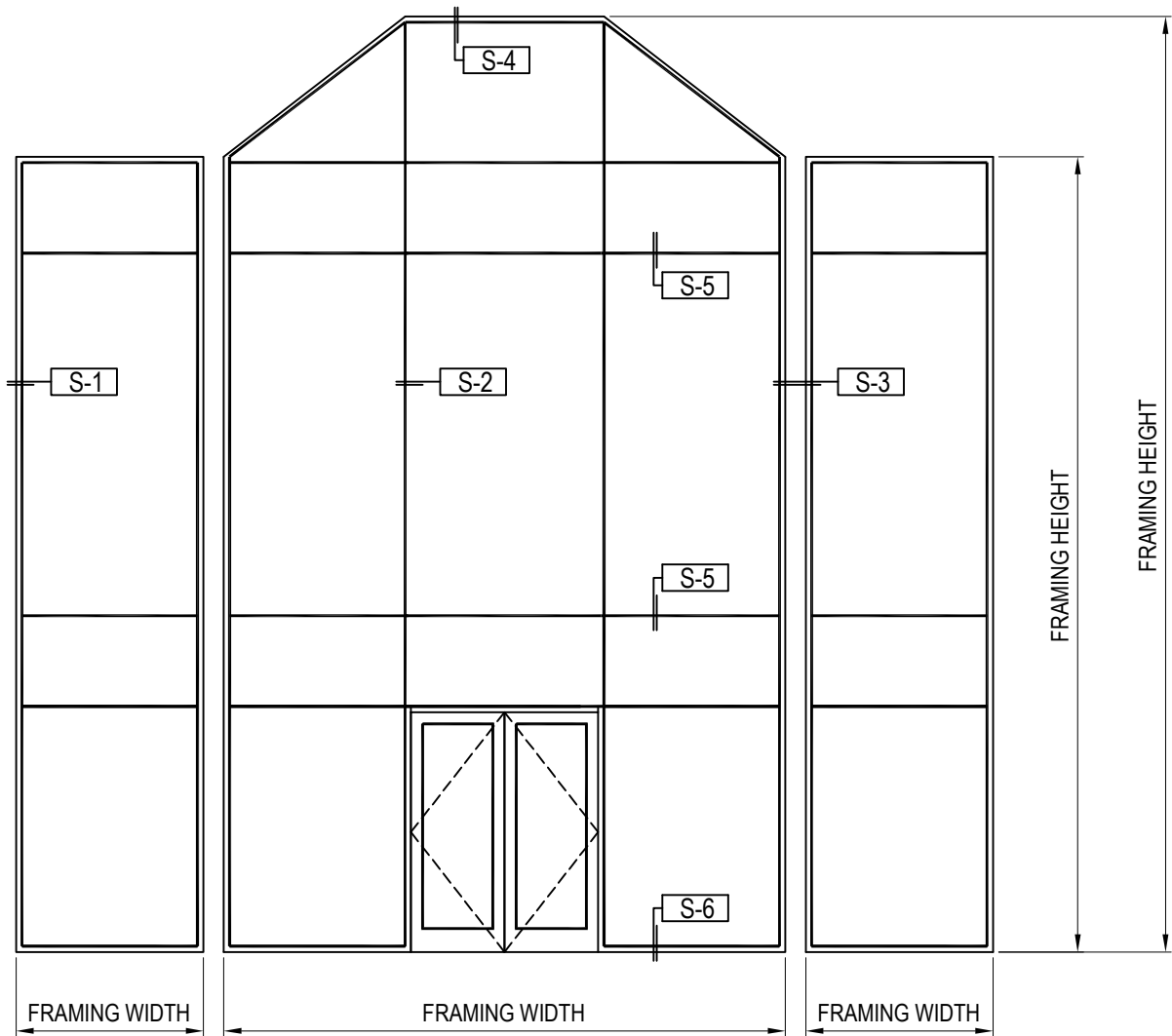

DESIGN FEATURES:

UNRESTRICTED PROFILE AND SIZES

PREFINISHED GALVANIZED STEEL, STAINLESS STEEL AND BRONZE

DEPTH AND SITELINE CAN BE ADJUSTED TO MEET DESIGN AND PERFORMANCE NEEDS (SHOWN AS 2" X 6" OVERALL)

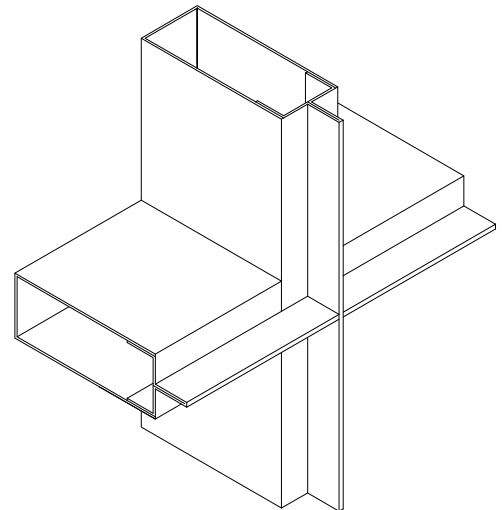

STRUCTURAL GLAZE

MECHANICAL ASSEMBLY

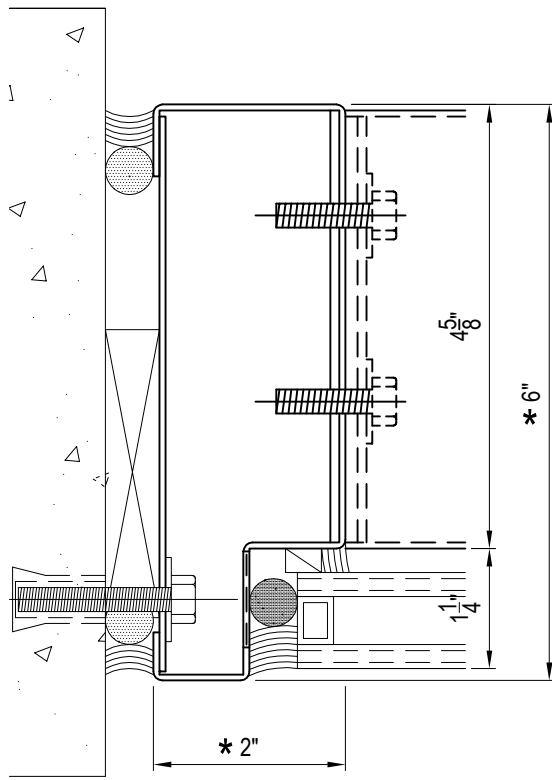

S-1

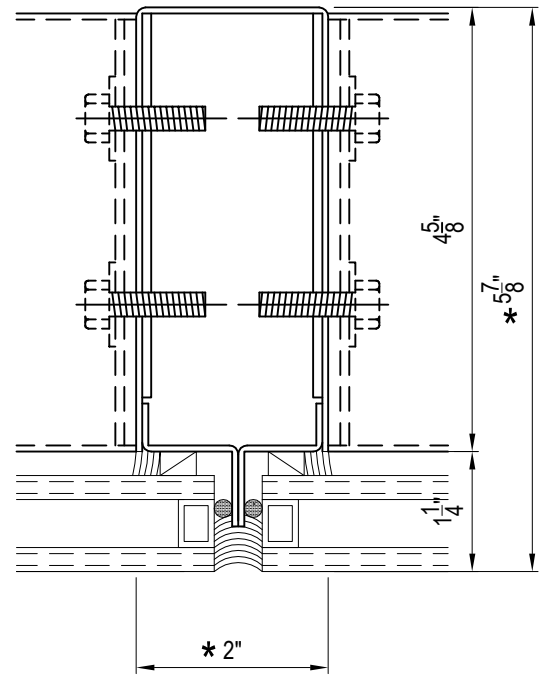

S-2

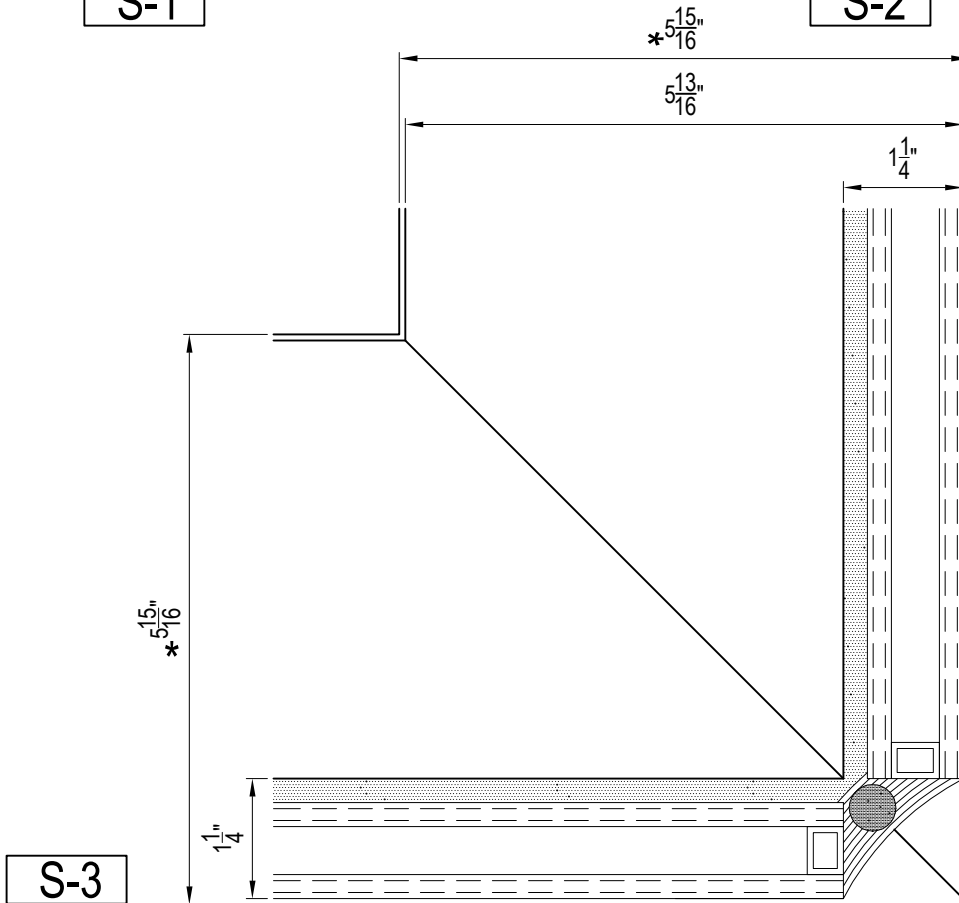

S-3

* SIZE OF PROFILE CAN BE ADJUSTED
ACTUAL DESIGN OF PROFILE MAY CHANGE

STRUCTURAL GLAZE

SECTION DETAIL

S-4

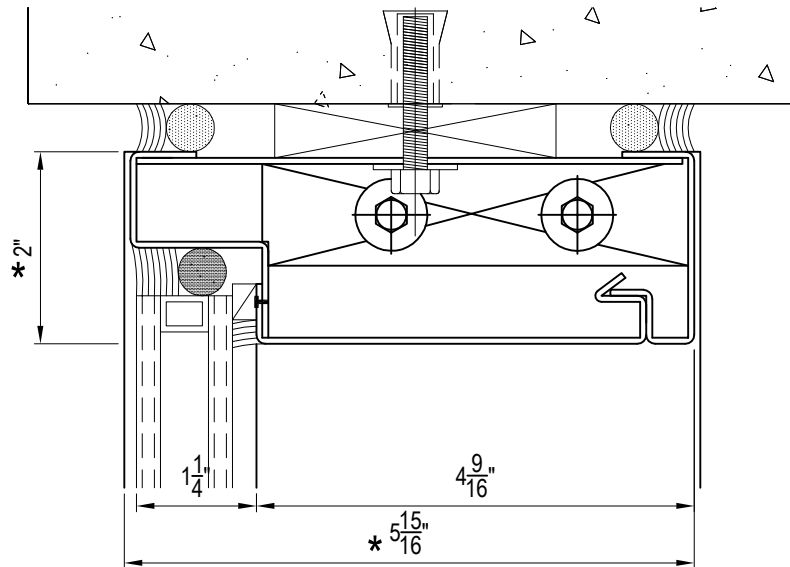

S-5

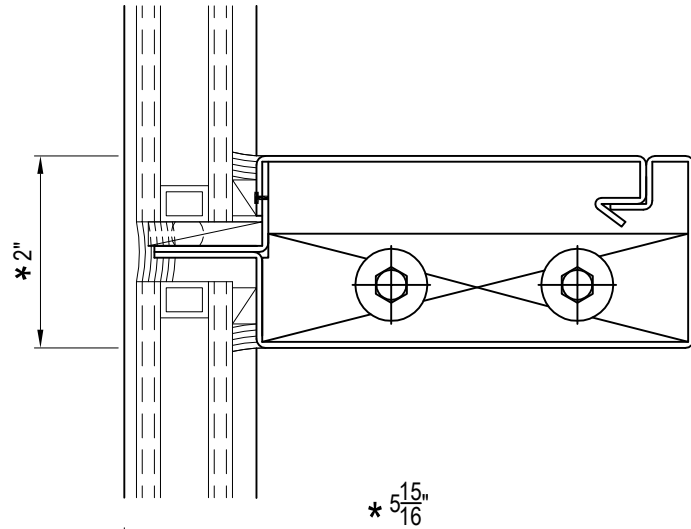

S-6

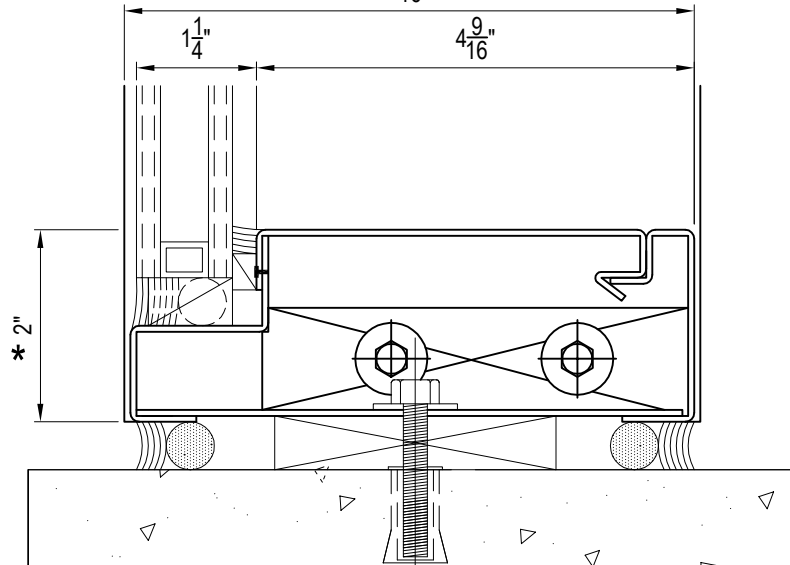

* SIZE OF PROFILE CAN BE ADJUSTED
ACTUAL DESIGN OF PROFILE MAY CHANGE

STRUCTURAL GLAZE

SECTION DETAIL

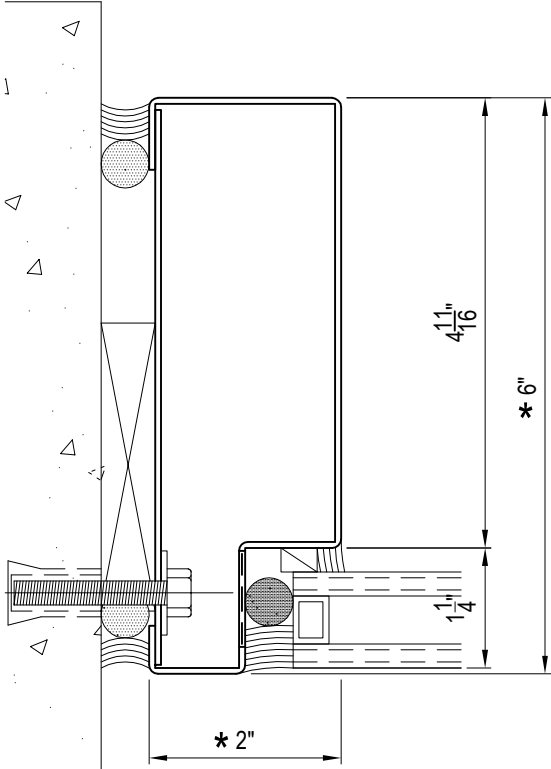

S-1

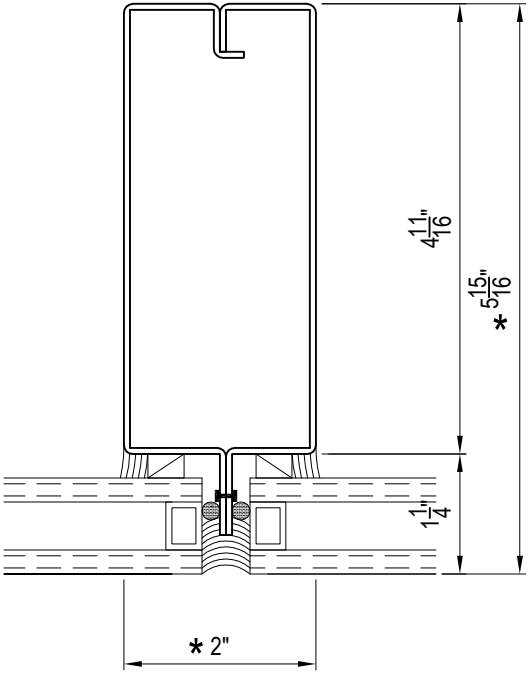

S-2

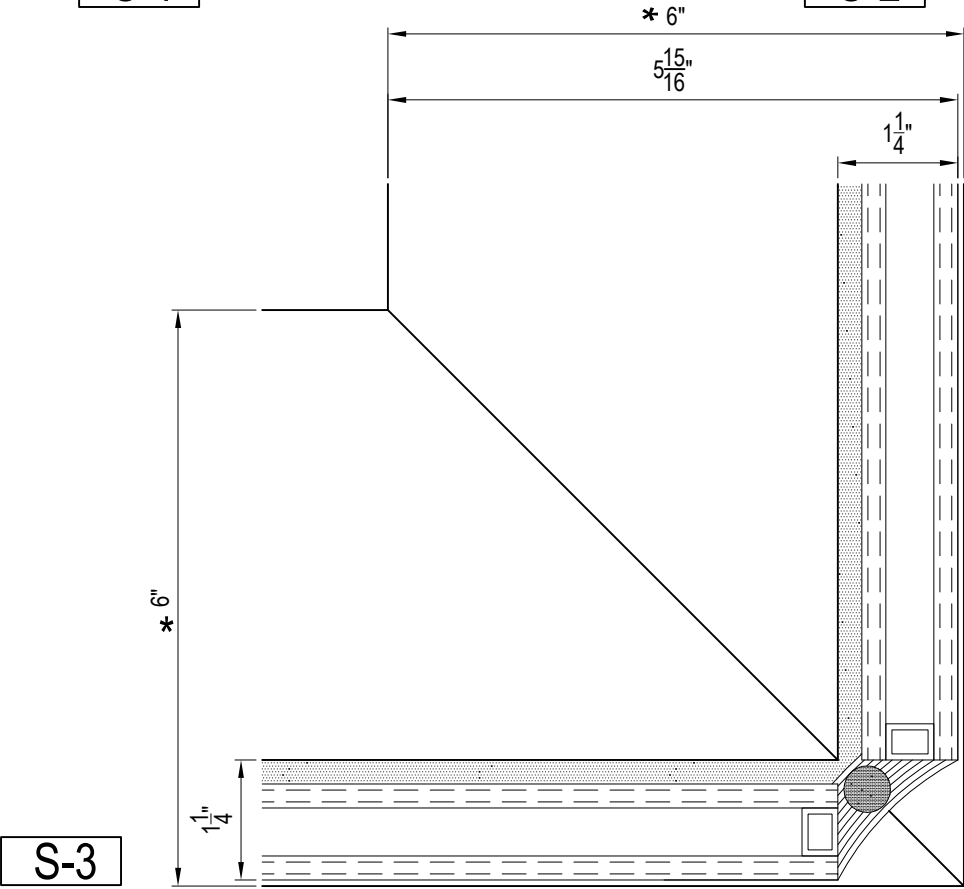

S-3

* SIZE OF PROFILE CAN BE ADJUSTED
ACTUAL DESIGN OF PROFILE MAY CHANGE

STRUCTURAL GLAZE

SECTION DETAIL

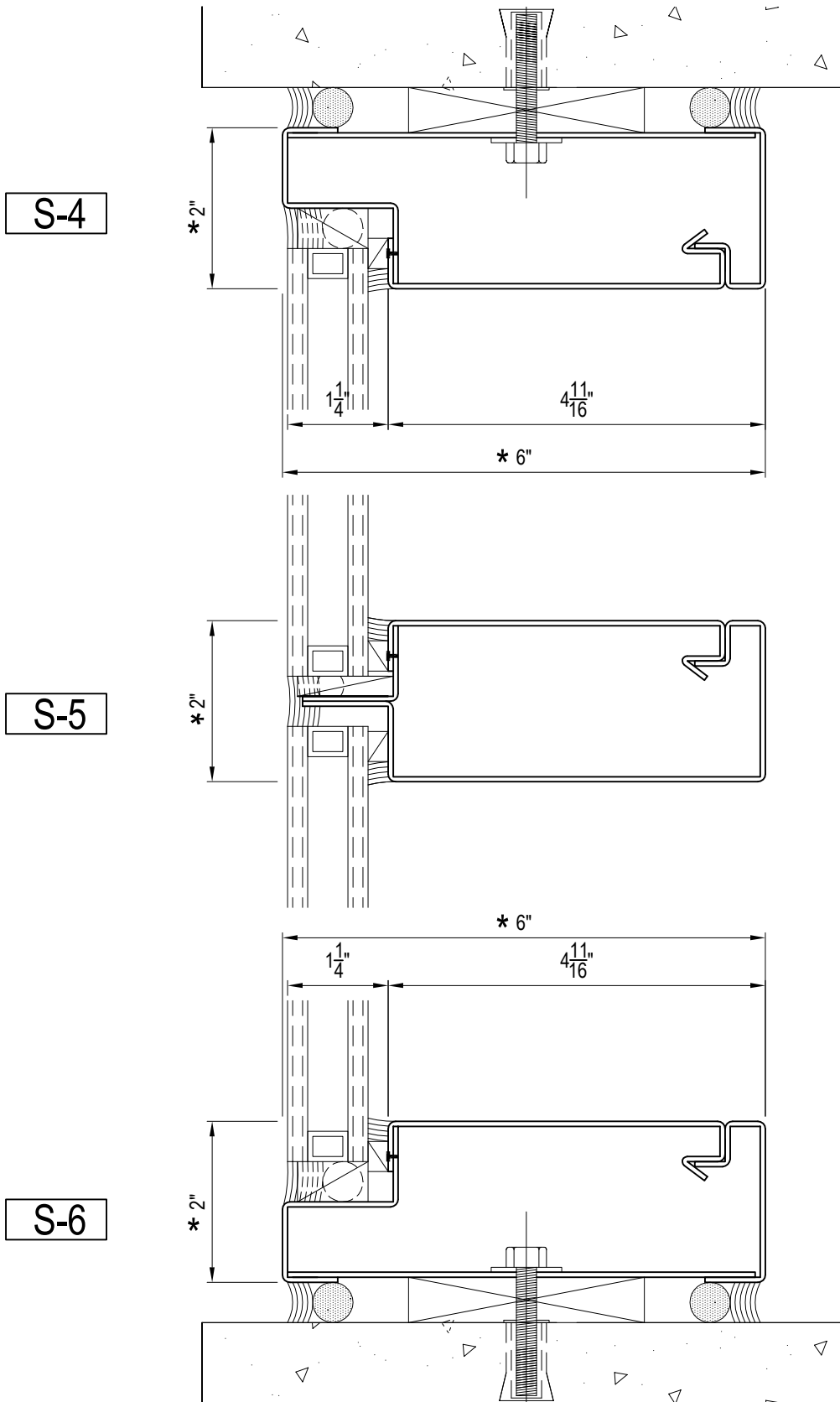

* SIZE OF PROFILE CAN BE ADJUSTED
ACTUAL DESIGN OF PROFILE MAY CHANGE

STRUCTURAL GLAZE

SECTION DETAIL

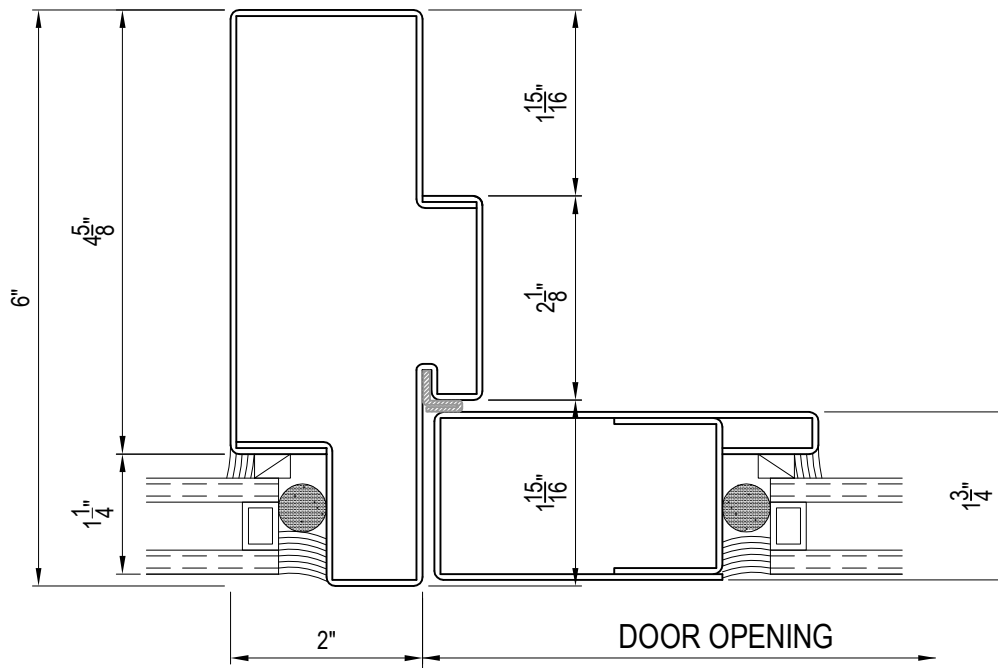

DOOR JAMB

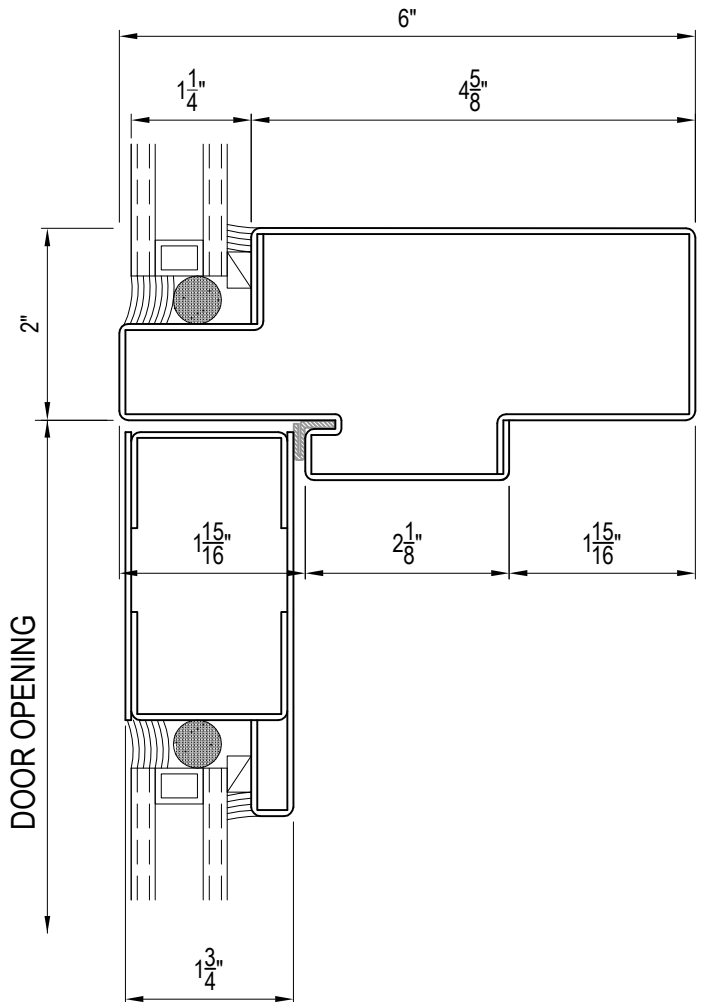

DOOR HEADER

NOTES:

DOORS AND DOOR FRAMES SHALL BE PREPED FOR ALL MORTISED HARDWARE

ALL SURFACE MOUNTED HARDWARE ATTACHEMENT HOLES TO BE DONE BY INSTALLER

* SIZE OF PROFILE CAN BE ADJUSTED
ACTUAL DESIGN OF PROFILE MAY CHANGE

STRUCTURAL GLAZE

SECTION DETAIL

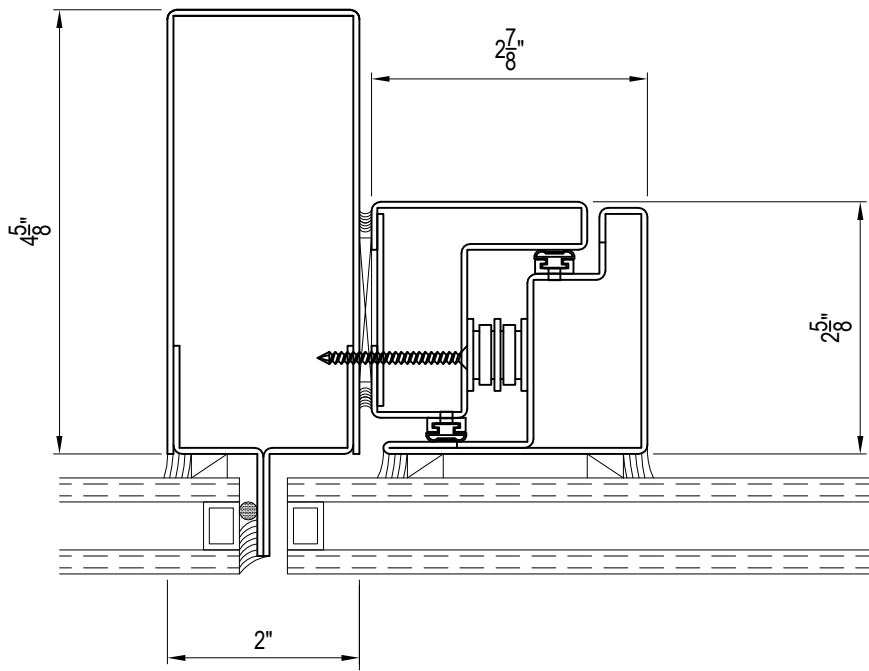

VENT SECTION

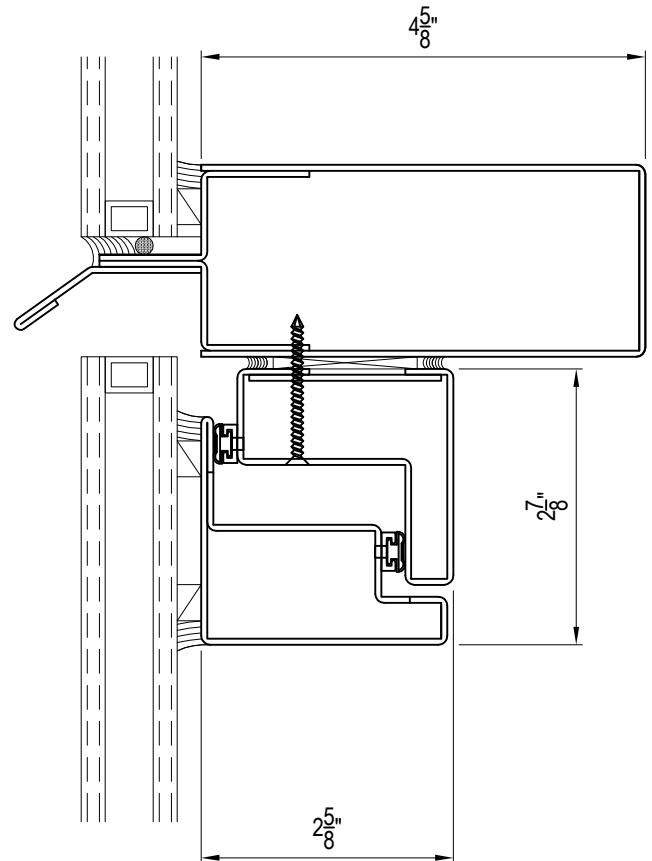

VENT SECTION

NOTES:

OPERABLE VENTS SHALL INCLUDE THE FOLLOWING HARDWARE:
 4 BAR STAINLESS STEEL HINGE
 STAINLESS STEEL LATCHING DEVICE
 WEATHERSTRIPPING

OPERABLE VENTS SHALL BE PREHUNG

* SIZE OF PROFILE CAN BE ADJUSTED
 ACTUAL DESIGN OF PROFILE MAY CHANGE

STRUCTURAL GLAZE

SECTION DETAIL

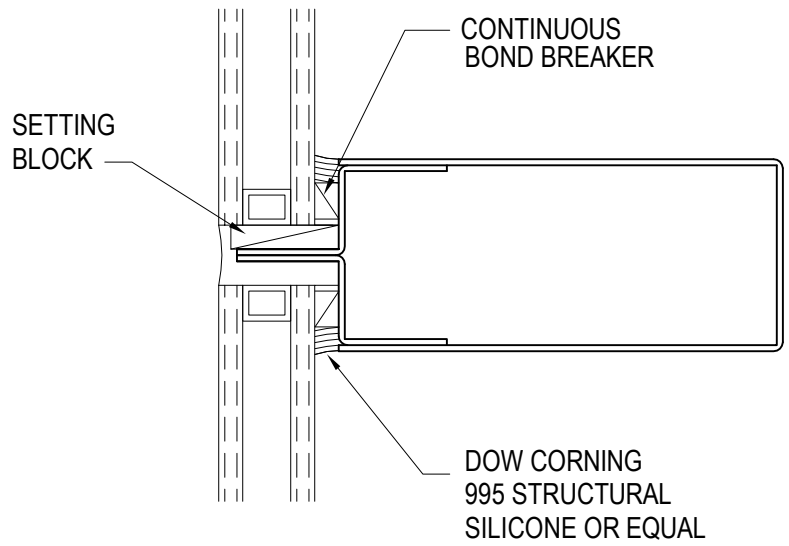

TYPICAL STRUCTURAL GLAZING

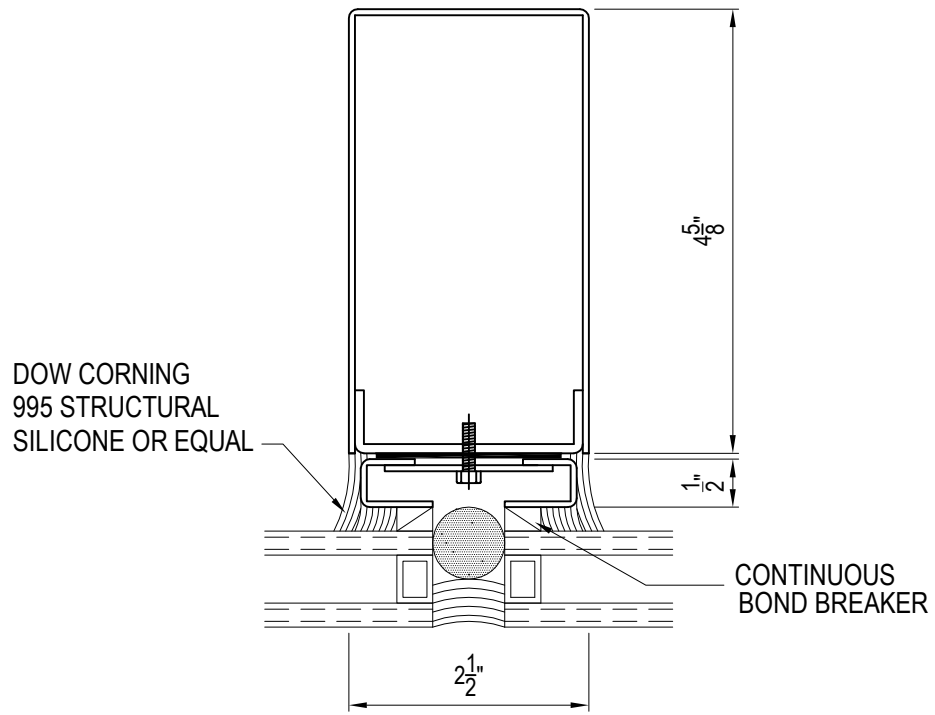

CARRIER FRAME SYSTEM

ACTUAL DESIGN OF PROFILE MAY CHANGE

STRUCTURAL GLAZE

GLAZING OPTIONS

16 GAGE NON-REINFORCED STEEL FRAMING
I=VALUES

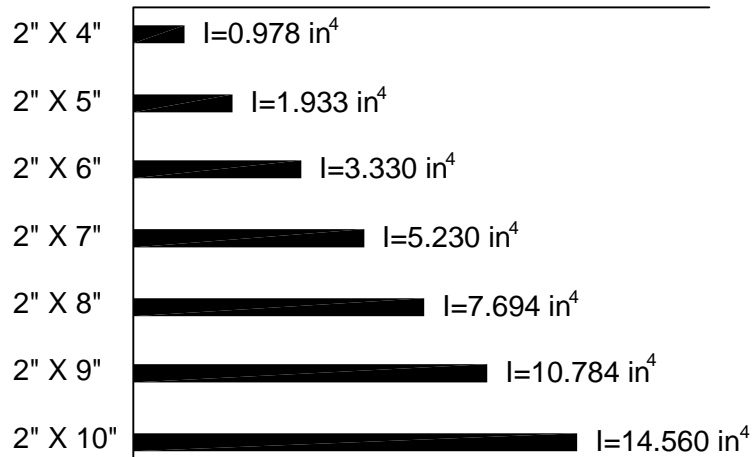

16 GAGE WITH 14 GAGE REINFORCED STEEL FRAMING
I=VALUES

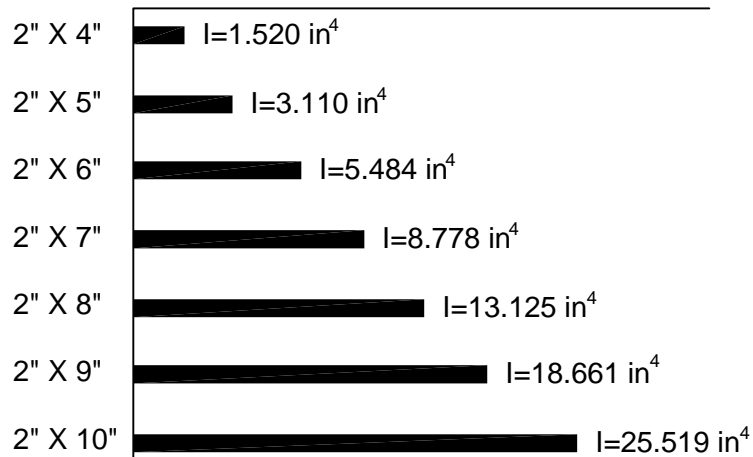

16 GAGE WITH 3/16" THK REINFORCED STEEL FRAMING
I=VALUES

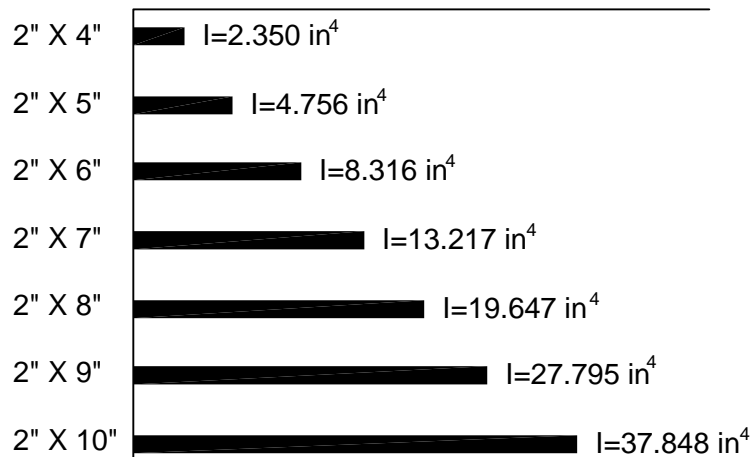

STRUCTURAL GLAZE

I=VALUES

STRUCTURAL GLAZED WINDOW WALL AND CURTAINWALL SECTION 08900

PART 1 – GENERAL

1.01 Work included

- A. Work shall include but not be limited to formed steel Structural Glaze curtainwall, trim and anchors, as shown on the architectural drawings.
- B. Related Work
 - 1. Glass, glazing, and glazing materials:
Section 08800
 - 2. Perimeter caulking and sealing:
Section 07900
 - 3. Miscellaneous structural items:
Section 05500

1.02 System Performance Requirements

- A. Design Wind Loads
 - The design wind pressure for the project will be:
 - 1. ___ psf positive and negative; ___ psf negative at corner zones
 - 2. Per wind pressure diagram
 - 3. Per local building codes
- B. Air Infiltration Test:
ASTM E283 – Maximum air infiltration 0.06 CFM per square foot with a pressure differential of 6.24 PSF (50 MPH)
- C. Water Penetration Test
ASTM E331 – No water penetration for 15 minutes when the window is subjected to a rate of flow of 5 Gal./Hr./Sq. Ft. with a pressure differential of 12.00 PSF.
- D. Structural
 - 1. Uniform Load Deflection Test:
No deflection of any unsupported span of test unit in excess of L/175 at both a positive and negative load of the design test pressure when tested in accord with ASTM E330 (L/240 + 1/4" at spans over 13'-6")
 - 2. Uniform Load Structural Test:
Unit to be tested at 1.5 x design pressure, both positive and negative, acting normal to plane of wall in accord with ASTM E330.
- E. Meet or exceed the Steel Window Institute (SWI) and AAMA "Metal Curtainwall Manual" specifications as indicated and/or modified by the specifications herein.

1.03 Submittals

- A. Submit shop drawings showing curtainwall and installation details, including anchorage, fastening and recommended sealing methods. Show dimensioned elevations with opening and curtainwall sizes. Upon request, provide test reports for all pertinent standards.
- B. Samples
Submit samples of assembled corner sections and other materials and components as requested by the Architect.

1.04 Warranty

- A. Submit a written warranty for a period of 3 years from the date of substantial completion against defective materials, which result in the premature failure of the curtainwall frames or factory applied finish.

PART 2 – PRODUCTS

2.01 Approved Manufacturers

- A. Drawings are based upon **StileLine™** Structural Glaze Series a division of Stiles Custom Metal
- B. Substitutions
 - 1. Other manufacturers that meet or exceed specifications must submit test reports and proposal details at least 10 working days prior to bid date for consideration.
 - 2. Substitute products not pre-approved by the Architect via Addendum will not be considered.

2.02 Materials

- A. The frames shall be composed of the following:
 - 1. Galvanized steel formed sheet: Commercial Quality, complying with ASTM A526, chemically treated, extra smooth, not oiled, and coated in accordance with ASTM A525, A60 designated, all spangles wiped free.
- Or:
 - 2. Stainless steel formed sheet: Alloy 304 and 316 Commercial Quality, complying with ASTM A526
- Or:
 - 3. Bronze steel formed sheet: Architectural bronze, CDA alloy 464 Naval Brass
- B. Structural Tubing: ASTM A500, Cold Formed, Welded Seamless Carbon Steel, in Rounds & Shapes.
- C. The frame sections shall have a front to back depth dimension of _____ and be a minimum thickness of 16 gauge.
- D. Glass: Provide in accordance with Section 08800.
- E. Glazing: Provide in accordance with Section 08800.
- F. Glazing Materials: Provide in accordance with Section 08800.

2.03 Fabrication

- A. Shop to fabricate frames as complete units. No fabrication will be permitted on the job site. Fabricate curtainwall in accordance with the approved shop drawings.
- B. No dissimilar metals shall be in contact that would cause electrolytic corrosion.
- C. Weld along entire line of hairline contact in accordance with AWS Welding Codes or Mechanically Join all corners.
- D. No discoloration grind marks or heat sinks will be visible if welded and dressed.
- E. System to be fully pressure-equalized at the interior plane of the glazing pocket.
- F. Provide weep holes and/or drainage slots within the glazing pockets to drain any water within the system to the exterior.
- G. Finish:
 - 1. Galvanized Steel:
 - a. Hot dipped galvanized steel; Provide manufacturer's Tnemec two coat organic coating finish in accordance with general requirements Section 09870.
 - b. Pre treatment: Thoroughly clean steel with liquid and vapor degrease to conform to FS TT-C-490.
 - c. Cold Galvanizing: Apply sprayed on zinc to replace all damaged galvanized surfaces during punching, welding and grinding.
 - d. Primer: Coat pre treated material with Tnemec Series 69 Hi-Build Epoxoline II Primer with a dry film thickness of 3 mils.
 - e. Finish: Provide manufacturer's Tnemec two coat organic coating finish.
 - 2. Stainless Steel: To be provide with surface finish as per architects specifications
 - 3. Bronze: To be provide with surface finish as per architects specifications

PART 3 – EXECUTION

3.01 Inspection

- A. Curtainwall openings shall conform to details and dimensions shown on the approved shop drawings.
- B. The General Contractor prior to installation must correct conditions that may adversely affect the curtainwall installation.

3.02 Installation

- A. Experienced personnel shall install curtainwall specified under this section.
- B. Install curtainwall in strict accordance with the approved shop drawings and all local, state, and national laws and building codes.
- C. Set curtainwall plumb, level, and true to line, without warp or rack of frames.
- D. Anchor curtainwall securely to surrounding construction with approved fasteners.
- E. The exterior joints between the curtainwall, trim and mullions shall be properly sealed watertight with an approved sealant and be neatly pointed.
- F. Any abraded surface of the curtainwall finish shall be cleaned and touched up with air dry paint, ad approved and furnished by the curtainwall manufacturer, in a color to match the factory applied finish.
- G. Provide a continuous heel bead of silicone around the perimeter of all glass lights prior to the installation of exterior pressure plates and covers

3.03 Cleaning

- A. The General Contractor shall be responsible for protecting the curtainwall and related materials during storage on the job and during and after installation.
- B. Curtainwall installer shall leave the curtainwall surfaces clean after installation, exercising care to avoid damage to protective coatings and finishes.
- C. Any protection necessary due to the cleaning of materials adjacent to the curtainwall shall be the responsibility of the General Contractor.

END OF SECTION